

## FullHouse 1, 2, 3, 5 & C

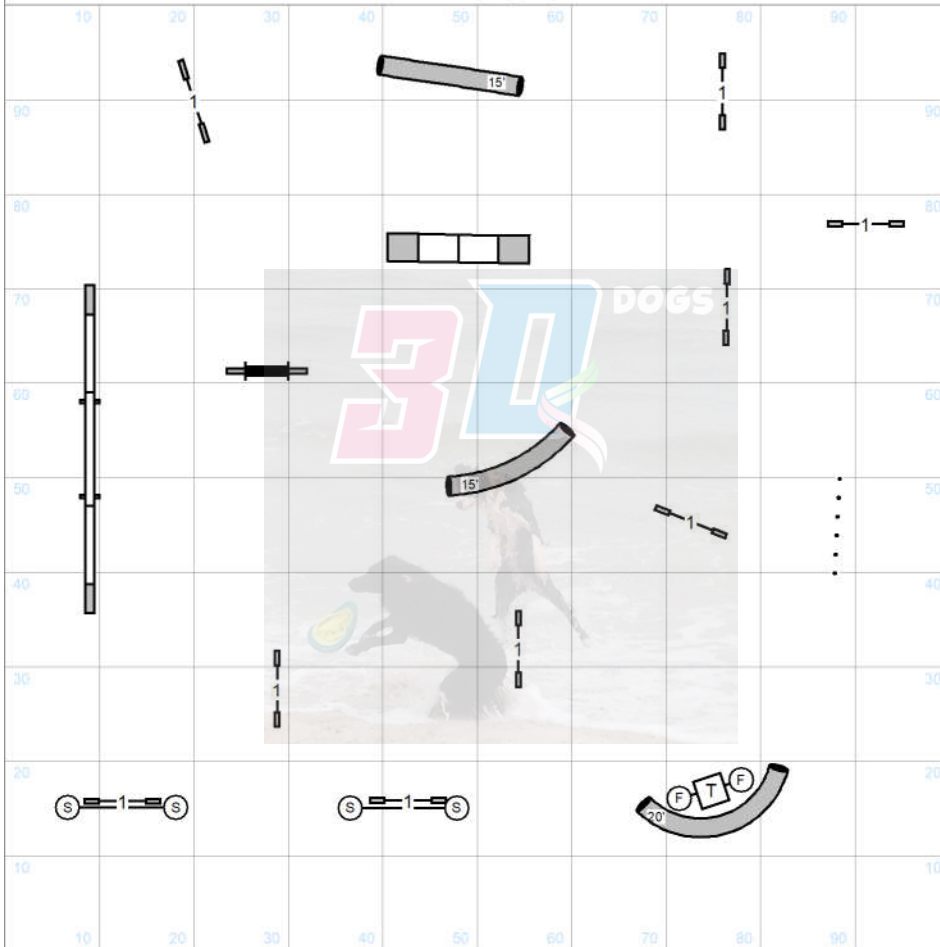

**You must start with one of the two Start line jumps. They are bi-directional**

**BRIEFING:** The table is live at all times after you receive the "Go."

All obstacles may be taken twice for points and back to back obstacles are allowed if done safely.

To qualify, you must obtain the required obstacles, which are three (3) 1 point obstacles, two (2) 3 point obstacles and one (1) 5 point obstacle and the additional points to complete your level.

Once you complete your point accumulation, you may go to the table at any time. Once the horn blows, you have 5 seconds for your dog to touch the table to stop the clock, or lose one point per full second over time

1 Point: Single bar jumps  
3 Point: Tunnels, Panel  
5 Point Jokers: Aframe, Weaves, Dogwalk

Times: Large Dogs: 30 seconds; Small Dogs: 35 seconds; 16" vets jumping 12" get big Dog time.  
Level 1 19 points  
Level 2 21 points  
Level 3 23 points  
Level 5, C 25 points  
Specialists and Enthusiasts: Two points fewer

FullHouse Level 1, 2, 3, 5 & C  
Judged by Darryl Warren  
Sep 14, 2024  
Teamworks Dog Training  
Youngsville, NC

CourseDesigner.com (CD i434)

# Standard 5 & C

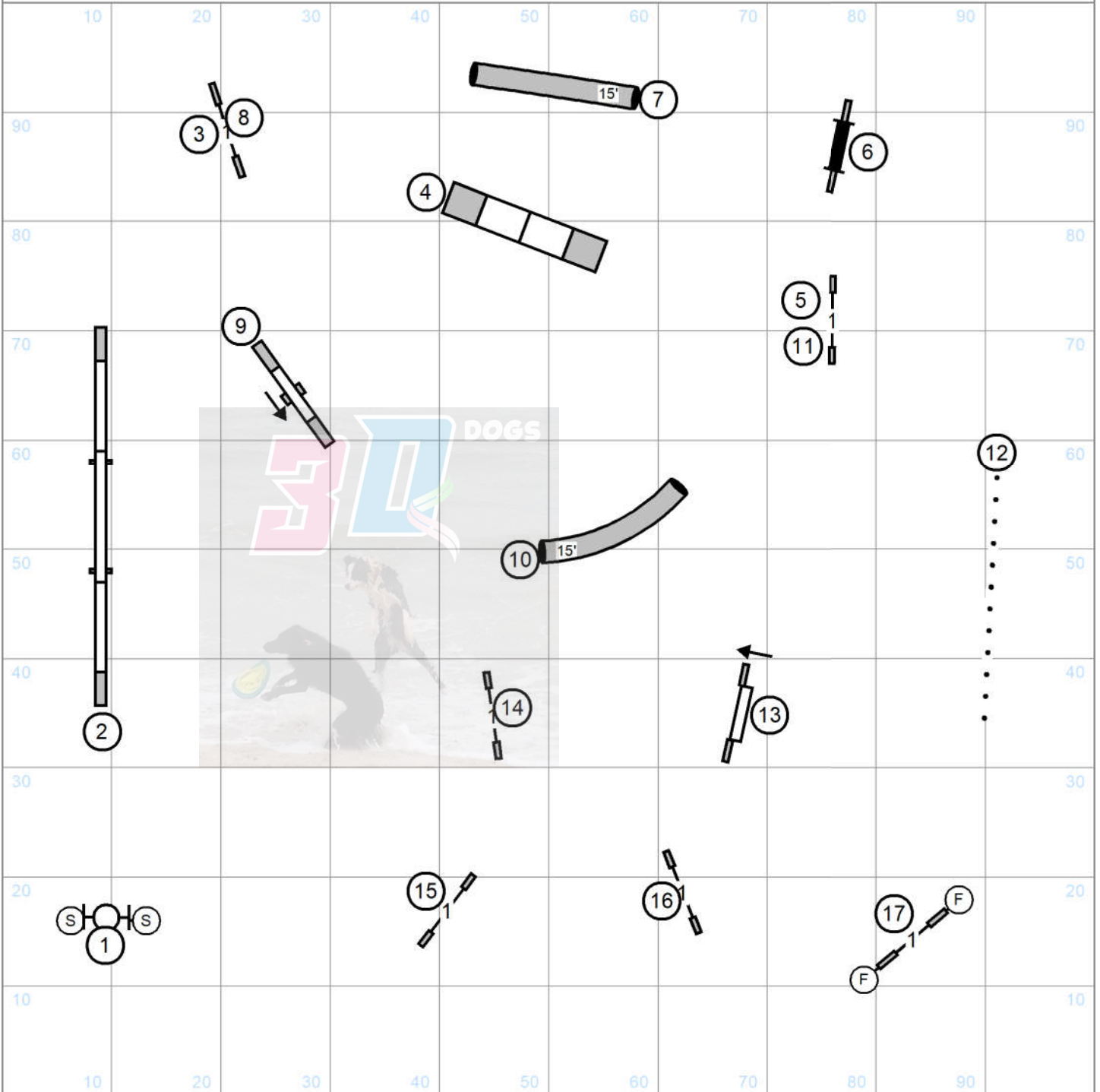

Please enter at # 15  
Good Luck

Standard Level 5 & C  
Judged by Darryl Warren  
Sep 14, 2024  
Teamworks Dog Training  
Youngsville, NC

# Standard 3

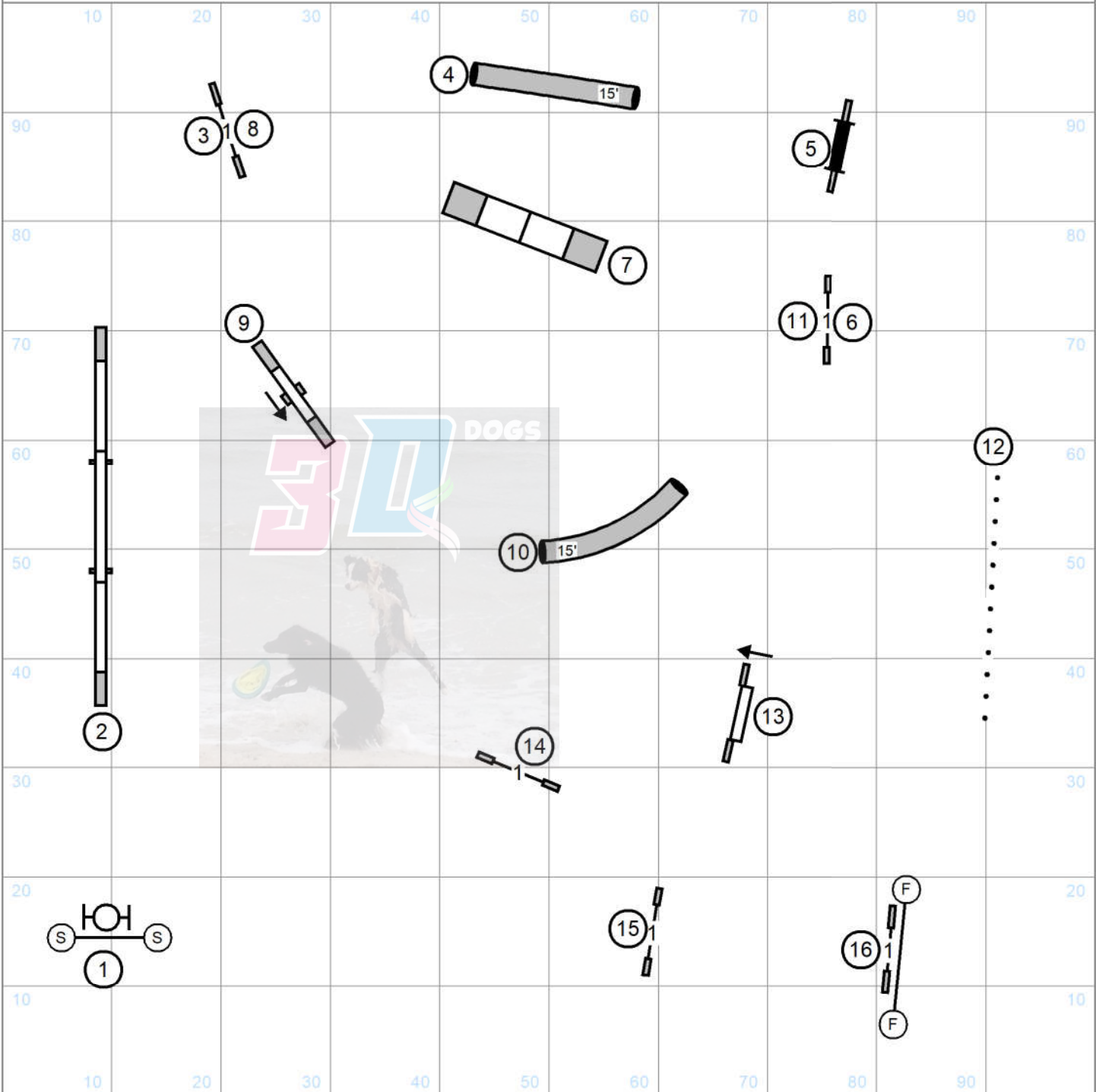

Please enter at # 15  
Good Luck

Standard Level 3  
Judged by Darryl Warren  
Sep 14, 2024  
Teamworks Dog Training  
Youngsville, NC

# Standard 2

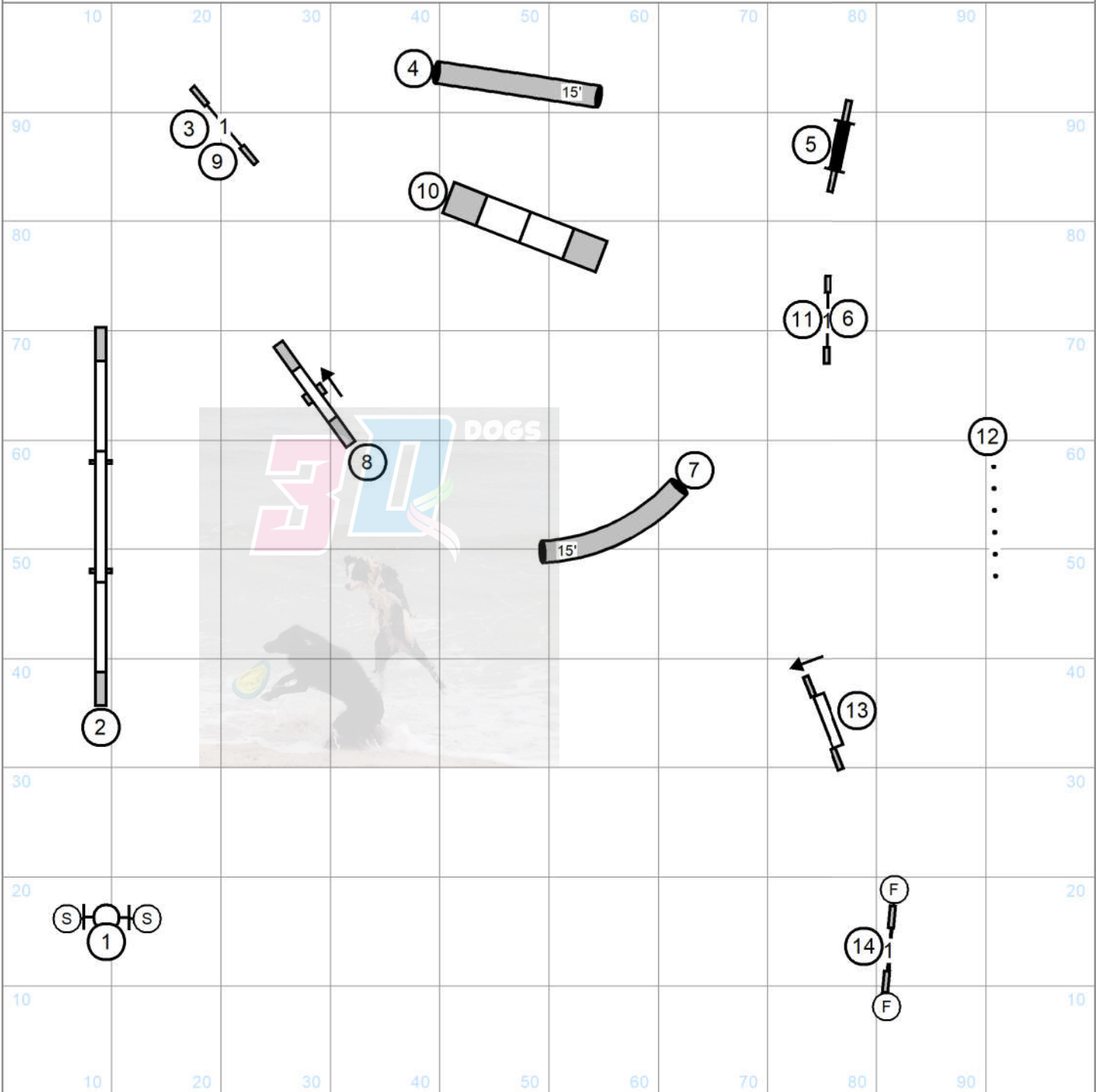

Please enter at # 12  
Good Luck

Standard Level 2  
Judged by Darryl Warren  
Sep 14, 2024  
Teamworks Dog Training  
Youngsville, NC

# Standard 1

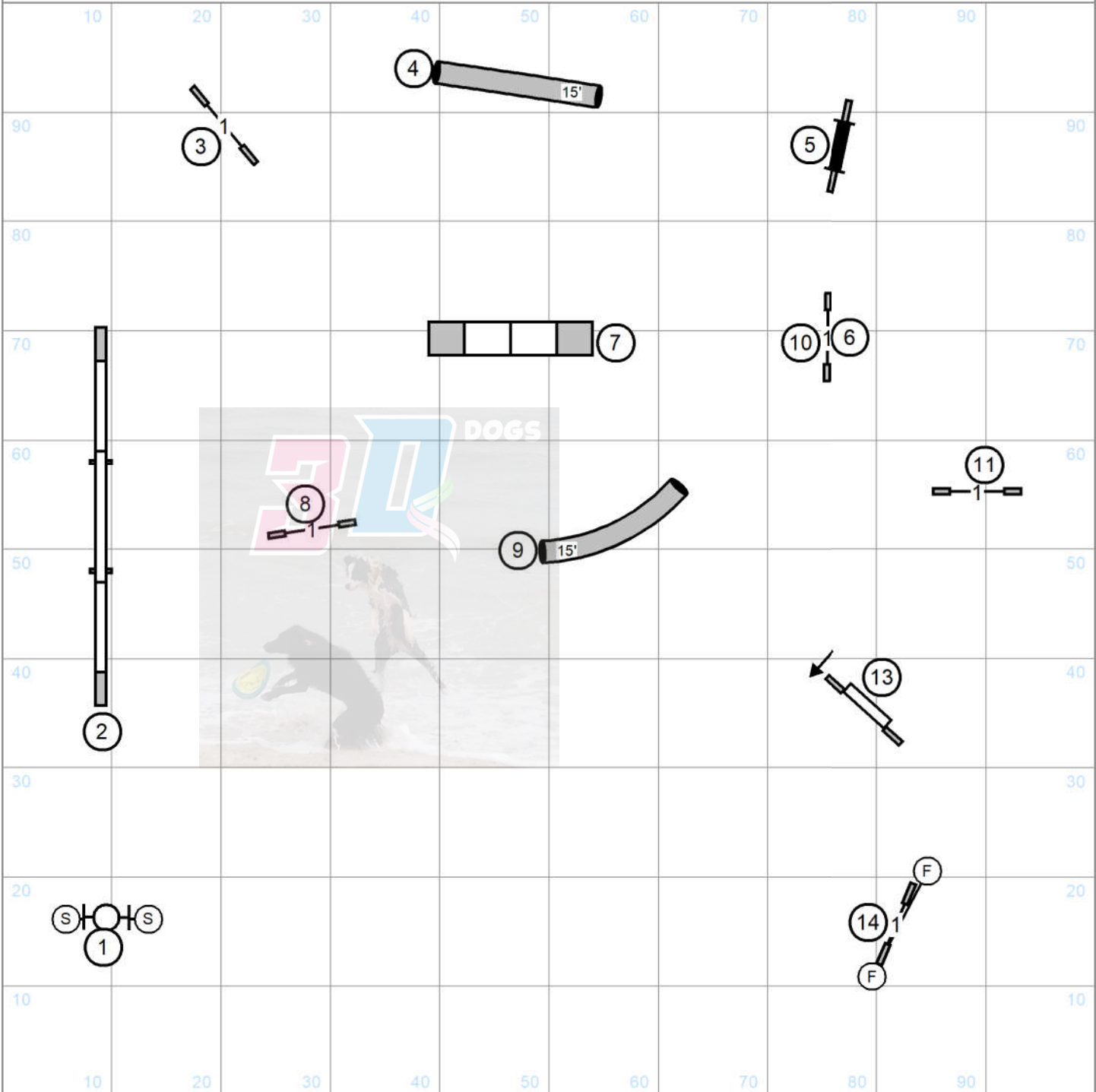

Please enter at # 11  
Good Luck

Standard Level 1  
Judged by Darryl Warren  
Sep 14, 2024  
Teamworks Dog Training  
Youngville, NC



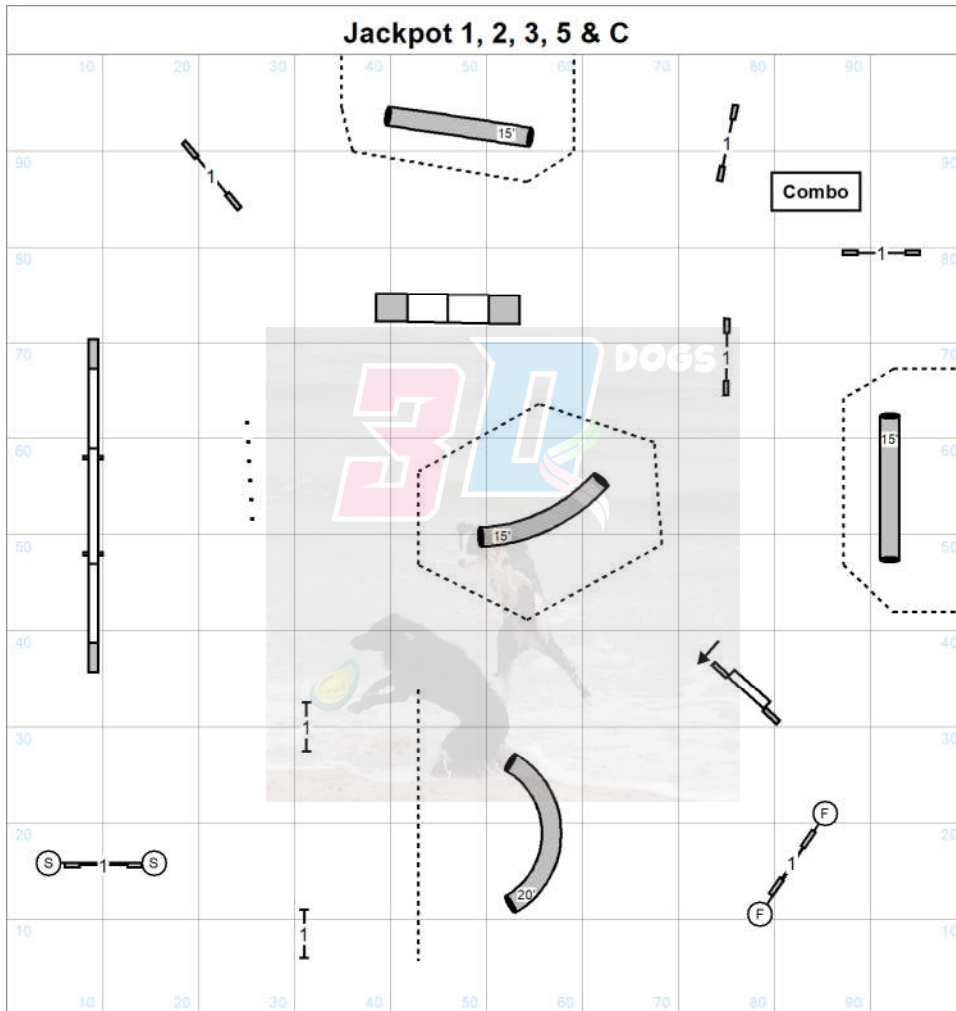

Jackpot Level 1, 2, 3, 5 & C  
 Judged by Darryl Warren  
 Sep 14, 2024  
 Teamworks Dog Training  
 Youngville, NC

**Start Jump Bi Directional**

Point Values:

1 pt.- Jumps

3 pts.-Weaves, Tunnel, Double

5 pts.-A-Frame, Dogwalk, Combo

**The Aframe is worth 7 Points the first time it is attempted.**

Everything may be done twice successfully for points in the opening and twice more in the closing, back-to-back is fine as long as it is done safely

During the Opening doing a tunnel from behind the line doubles the next Obstacle Value. That would include doing the same tunnel.

The Finish Jump is not live until after the first buzzer BUT if a team wants to end their run early they may do so by directing their dog to the Finish Jump. The Finish Jump is Bi- Directional. The Finish Jump has no value.

In order to Q a team must:

- 1-Accumulate enough points for their level
- 2-Get to the finish jump without going over time.

Remember- In Jackpot the second buzzer doesn't sound until you are 6 seconds over time, but if you're one full second over time you have NQd.

## Snooker 3, 5, & C

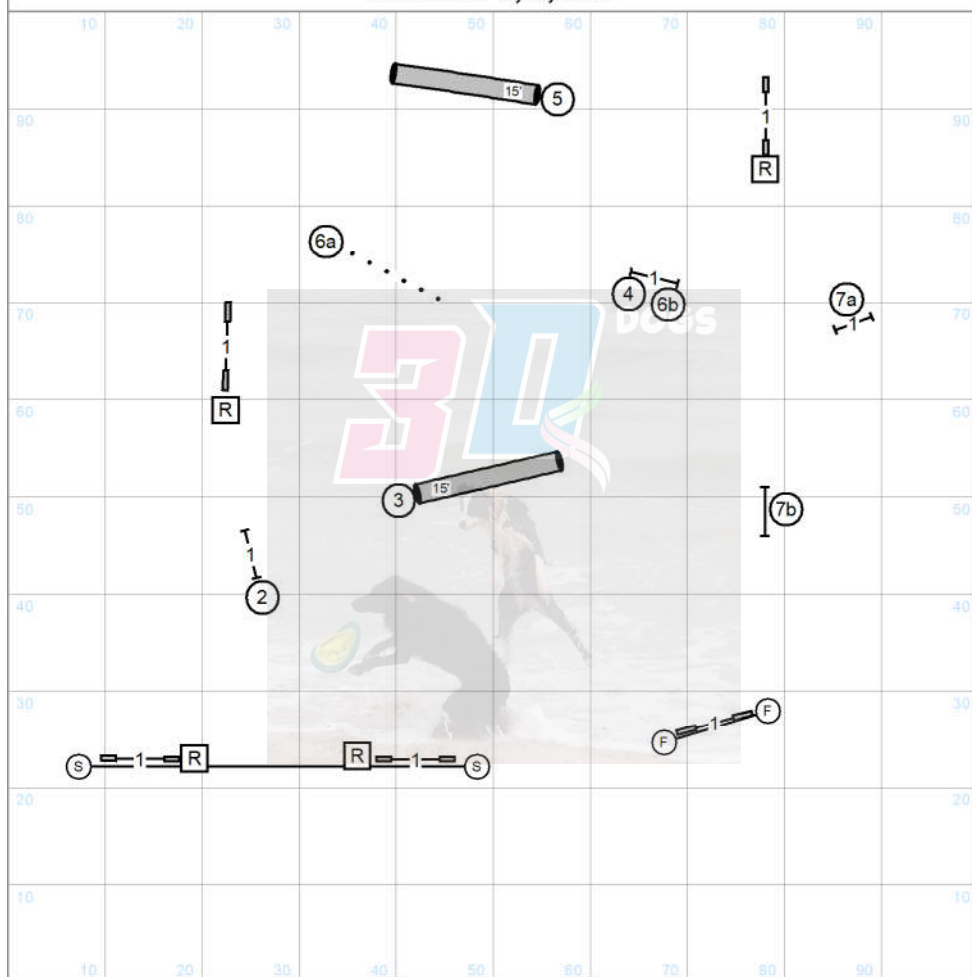

**The Start Line is not Bi-Directional**

Opening: successful red followed by any color, 3 times  
everything is bi-directional, combos in any order

The finish jump is live upon completion of the opening. Or if the handler directs the dog to take it in the opening.

Closing: 2-7 in order (#2 is Bi-directional), combos as labeled

Upon hearing the buzzer or "thank you," run to the finish. Continuing to run the course can result in losing the last points earned.

**Points:**

Level 3 30 points

Level 5, C 32 points

Enthusiast/Specialist –  
2 points fewer at each level

Snooker Level 3,5,& C  
Judged by Darryl Warren  
Sep 14, 2024  
Teamworks Dog Training  
Youngsville, NC

CourseDesigner.com (CD v4.34)

## Snooker 1 & 2

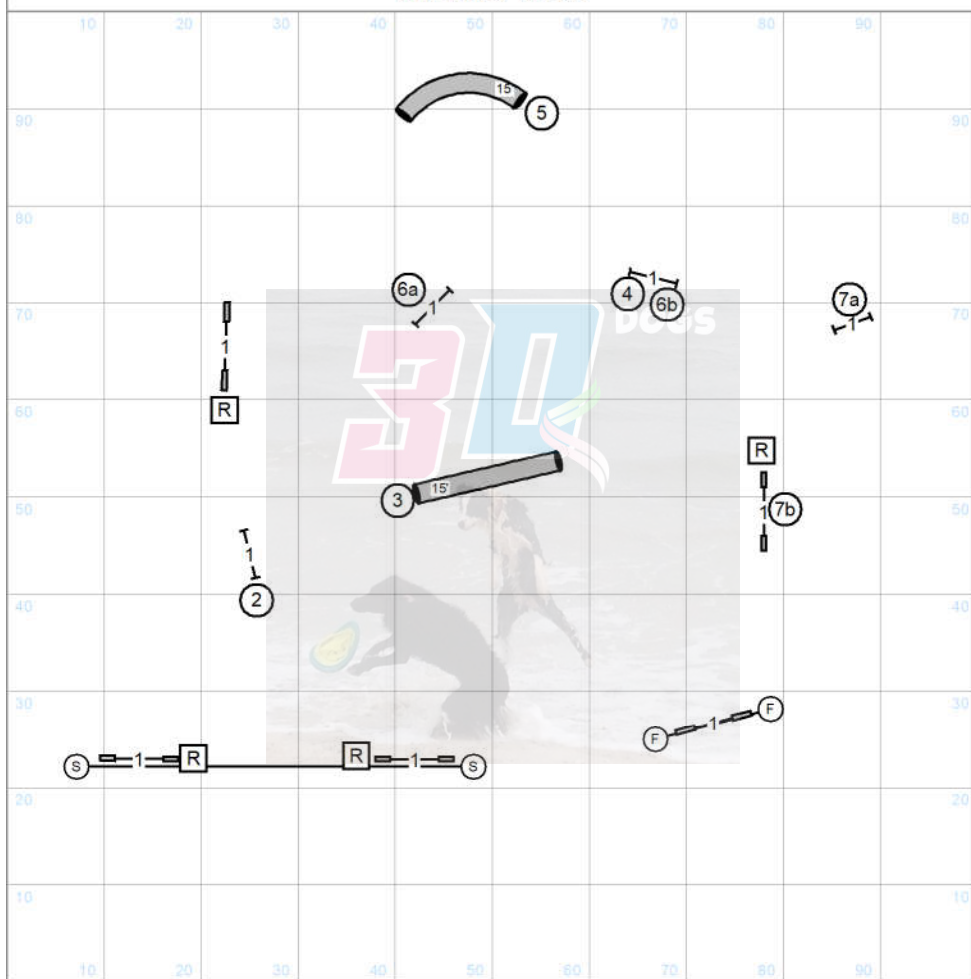

### The Start Line is not Bi-Directional

Opening: successful red followed by any color, 3 times  
everything is bi-directional, combos in any order

The finish jump is live upon completion of the opening. Or if the handler directs the dog to take it in the opening.

Closing: 2-7 in order ( #2 is Bi-directional), combos as labeled

Upon hearing the buzzer or "thank you," run to the finish. Continuing to run the course can result in losing the last points earned.

#### Points:

Level 1    26 points  
Level 2    28 points

Enthusiast/Specialist –  
2 points fewer at each level

Snooker Level 1 & 2  
Judged by Darryl Warren  
Sep 14, 2024  
Teamworks Dog Training  
Youngville, NC

CourseDesigner.com (CD v4.34)



# Jumpers 3, 5, & C

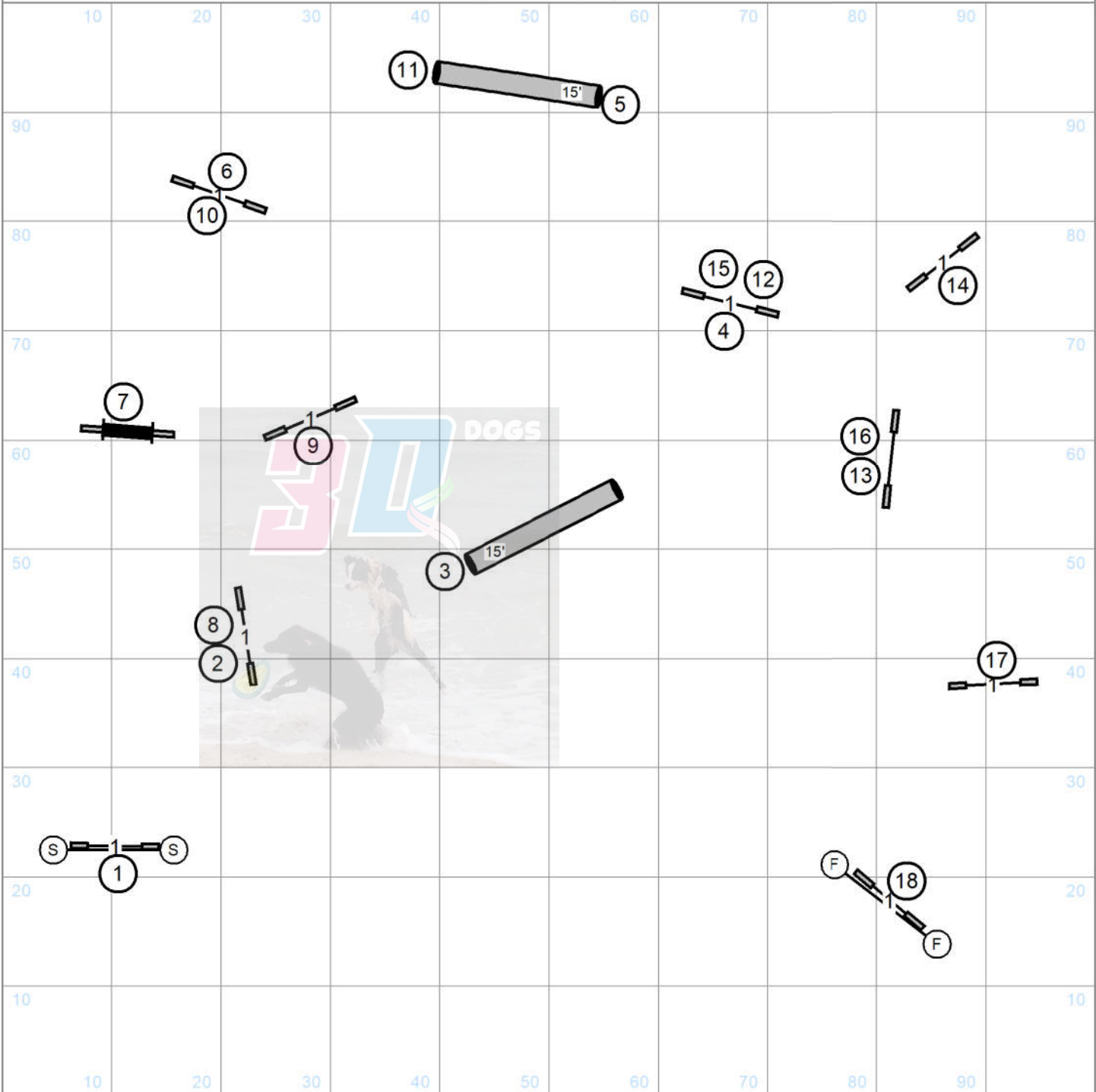

**Please enter at # 15**  
**Good Luck**

Jumpers Level 3,5,& C  
 Judged by Darryl Warren  
 Sep 14, 2024  
 Teamworks Dog Training  
 Youngville, NC

# Jumpers 1 & 2

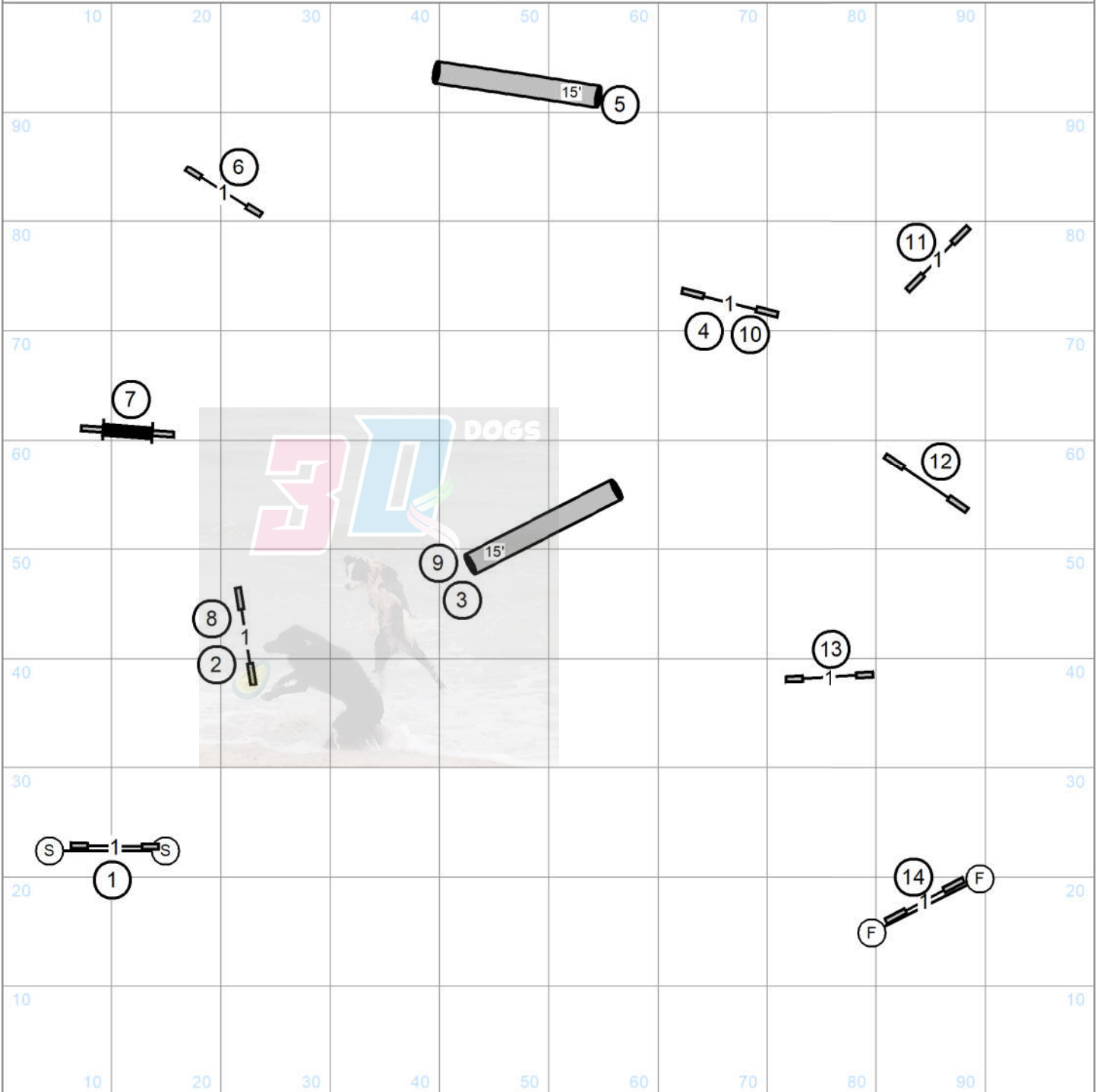

**Please enter at # 11**  
**Good Luck**

Jumpers Level 1 & 2  
 Judged by Darryl Warren  
 Sep 14, 2024  
 Teamworks Dog Training  
 Youngsville, NC